

## Investigation of Ship Hull Girder Strength with Grounding Damage

Muhammad Zubair Muis Alie<sup>1\*</sup> and Ristiyanto Adiputra<sup>2</sup>

1. Department of Ocean Engineering, Engineering Faculty, Universitas Hasanuddin, Gowa 92172, Indonesia

2. Department of Maritime Engineering, Engineering Faculty, Kyushu University, 744 Motooka Nishi-ku, Fukuoka 819-0395, Japan

\*e-mail: [zubair.m@eng.unhas.ac.id](mailto:zubair.m@eng.unhas.ac.id)

---

### Abstract

The objective of the present study is to investigate ship hull girder strength as a result of grounding damage upon longitudinal bending. A bulk carrier and tanker are analyzed and Smith's Method is adopted and implemented in the analysis program. An efficient solution procedure is performed by assuming the cross-section remains plane and the vertical bending moment is applied to the cross section. As a fundamental case, the damage is simply created by removing the elements from the cross section. Welding residual stress, initial imperfections, and crack extensions are not considered. The grounding damage is made by two conditions, namely those are placed at the center part of the cross section and those located at an asymmetric position. To determine the ultimate strength, which includes the progressive collapse behavior of ship hull with damage, the simply supported scenario is imposed to the cross section and hogging and sagging conditions are taken into account. The results obtained for intact and damage conditions by the in-house program are compared with one another to observe the collapse behavior in advance.

### Abstrak

**Investigasi Kekuatan Penumpu Lambung Kapal terhadap Kerusakan Tubrukan.** Tujuan dari penelitian ini adalah untuk menginvestigasi kekuatan lambung kapal dari kerusakan yang disebabkan oleh kandas dalam pengaruh lentur memanjang. Sebuah kapal *bulk carrier* dan *tanker* dipertimbangkan untuk dianalisis. Metode Smith diadopsi dan diterapkan kedalam program bantu. Suatu prosedur penyelesaian yang efisien dipaparkan, dengan kata lain mengasumsikan penampang kapal adalah bidang dan momen lentur vertikal diberikan pada penampang. Untuk perhitungan sederhana, kerusakan dibuat secara sederhana dengan menghilangkan elemen-elemen dari penampang, mengabaikan tegangan sisa pengelasan, ketidaksempurnaan awal dan retak tidak dipertimbangkan. Kerusakan oleh kandas dibuat dengan dua kondisi, yaitu ditempatkan pada bagian bawah tengah kapal dan ditempatkan pada posisi tidak simetris. Untuk menginvestigasi kekuatan kapal termasuk perilaku kehancuran progressive dari lambung kapal dengan kerusakan kandas, maka tumpuan sederhana diterapkan dengan mempertimbangkan kondisi *hogging* dan *sagging*. Hasil yang diperoleh untuk kondisi utuh (*intact*) dan rusak dengan program bantu dibandingkan antara satu dengan lain untuk mengamati perilaku kehancuran selanjutnya.

*Keywords: grounding damage, intact, longitudinal bending, ship hull, ultimate strength*

---

### 1. Introduction

Damage caused by grounding may occur in a ship's hull and threaten the safety of the ship and surrounding environment. This phenomenon must be investigated as one of the functional requirements for the ship's structural design. Many studies have described how an assessment of ship hull girder strength is very important. The development of the Residual Strength–Damage

Index (R-D) diagram for evaluating damaged structures, which takes into account the time-dependent corrosion wastage effect, has been presented [1].

The residual strength of an asymmetrically damaged ship hull girder under longitudinal bending was analyzed by Muis Alie [2]. The finite element method (FEM) for beams was used for the assessment of the residual strength for two single hull bulk carriers and a three-

cargo-hold model of a single-sided Panamax Bulk Carrier in hogging and sagging conditions. Muis Alie *et al.* [3] analyzed the residual strength of the ship hull girder with bottom damage. The nonlinear FEM was used and the full cross section was considered in the calculation. Muis Alie *et al.* [4] analyzed the hull girder ultimate strength for asymmetrically damaged ships using the FEM. The collision damage was modeled by removing the plate and stiffened plate elements.

Muis Alie *et al.* [5], assessed the ultimate hull girder strength of a roll-on/roll-off (ro-ro) ship after damage. The cross-section of a ro-ro ship was analyzed. Abubakar [6], presented a comparison of the resistance of stiffened panels to penetration damage with experimental data. This study also carried out comparisons between numerical simulations and experiments investigating the grounding of ships. The FEM and finite element analysis software were used to predict penetration damage. The modeling simulation was then extended to investigate damage to a ship's double bottom structure in different grounding scenarios.

Kim [7] established the residual ultimate longitudinal strength versus grounding damage index diagram (R-D diagram) for container ships. The proposed R-D diagram should be useful for defining acceptance damage criteria and making rapid salvage plans or rescue schemes from container ships that have sustained a grounding accident.

Saydam [8] presented a probabilistic framework for the performance of ship hulls after sudden damage and accounted for different operational conditions. Grounding and collision accidents were considered as sudden damage scenarios. The combined effects of sudden damage and progressive deterioration due to corrosion were investigated. Prestileo [9], covered a reliability assessment of the hull girder of a crude oil tanker and focused on a scenario in which the ship is exposed to sea loads after a damage to the bottom of the hull. A number of possible flooding configurations were examined, each one caused by a group of damage cases that were characterized by different location and extent.

Choung [10], provided two convergence criteria to find translational and rotational locations of the neutral axis plane (NAP) for intact and damaged vessels. Definitions for three types of asymmetries of a ship section were proposed: material, load, and geometry-induced. The concept of a moment plane was introduced to define the healing angle of a ship section. It was suggested that force equilibrium and force vector equilibrium criteria were simultaneously necessary to determine the new position of NAP due to both translational and rotational shifts. A new simplified deformation model was proposed comprising two folding elements. The second folding element compressed partly, and a new set of simplified analytical methods was developed by using the plastic

method analysis by Hong [11]. The proposed method was verified by the three experiments, which were used for the comparative study, and they agreed with the experimental results.

The collision resistance and residual strength of single side skin and double side skin bulk carriers subjected to collision damage was investigated by Ozguc [12]. The impact dynamic analyses were conducted using ANSYS LS-DYNA for the evaluation resistance forces, energy absorption, and penetration depth for various collision scenarios.

When grounding damage takes place for a ship hull, the bottom part will lose the rigidity due to the degradation of several elements. Therefore, it is very urgent to assess the ship hull girder after such an accident.

## 2. Progressive Collapse Analysis

Progressive collapse analysis was performed using a modified in-house program [13] to calculate the ship hull girder strength due to grounding damage under longitudinal bending moment. The axial stress,  $\sigma$ , corresponding to the axial strain,  $\varepsilon$ , was given by the average stress-average strain relationship calculated in advance for the individual elements, as illustrated in Figure 1. As a general case, grounding damage was assumed to be in an asymmetric position on the hull girder, as shown in Figure 2. The average stress-average

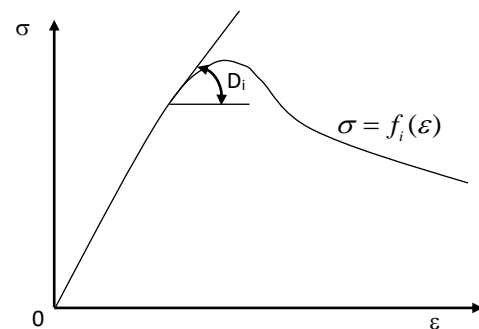

Figure 1. Average stress-Strain of an Element

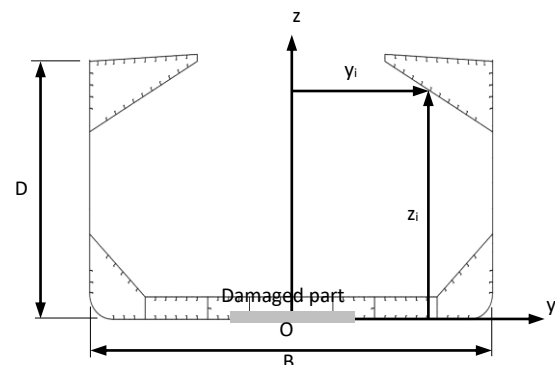

Figure 2. Cross Section with Damage

strain relationship, when considering buckling and yielding, is generally a nonlinear function of strain expressed as follows:

$$\sigma = f_i \varepsilon \quad (1)$$

Where  $f_i(0) = 0$ . The axial force,  $P$  the vertical bending moment,  $M_v$ , and the horizontal bending moment,  $M_H$ , can be obtained by integrating axial stresses over the intact part of cross section as follows:

$$P = \sum_{i=1}^n \sigma_i A_i \equiv 0 \quad (2)$$

$$M_H = \sum_{i=1}^n \sigma_i y_i A_i \quad (3)$$

$$M_V = \sum_{i=1}^n \sigma_i z_i A_i \quad (4)$$

Where  $N$  is the number of intact elements and  $A_i$  is a cross section of the  $i$ -th element.

$$\Delta \sigma = D_i \Delta \varepsilon \left( D_i = \frac{df_i}{d\varepsilon} \right) \quad (5)$$

$$\varepsilon_i(y_i z_i) = \varepsilon_0 + y_i \phi_H + \phi_V \quad (6)$$

Using Eq.(5) and Eq.(6), the incremental forms of Eqs. (2)-(4) can be given by

$$\begin{Bmatrix} \Delta P = 0 \\ \Delta M_H \\ \Delta M_V \end{Bmatrix} = \begin{bmatrix} \bar{D}_{AA} & \bar{D}_{AH} & \bar{D}_{AV} \\ \bar{D}_{HA} & \bar{D}_{HH} & \bar{D}_{HV} \\ \bar{D}_{VA} & \bar{D}_{VH} & \bar{D}_{VV} \end{bmatrix} \begin{Bmatrix} \Delta \varepsilon_0 \\ \Delta \phi_H \\ \Delta \phi_V \end{Bmatrix} \quad (7)$$

where

$$\begin{aligned} \bar{D}_{AA} &= \sum_{i=1}^N D_i A_i \\ \bar{D}_{AH} &= \bar{D}_{HA} = \sum_{i=1}^N D_i y_i A_i \\ \bar{D}_{HH} &= \sum_{i=1}^N D_i y_i^2 A_i \\ \bar{D}_{AV} &= \bar{D}_{VA} = \sum_{i=1}^N D_i z_i A_i \\ \bar{D}_{VV} &= \sum_{i=1}^N D_i z_i^2 A_i \\ \bar{D}_{HV} &= \bar{D}_{VH} = \sum_{i=1}^N D_i y_i z_i A_i \end{aligned} \quad (8)$$

The expression of the axial force increment,  $\Delta P$ , of Eq.(7) can be rearranged in the form:

$$\begin{aligned} \Delta P &= \bar{D}_{AA} \Delta \varepsilon_0 + \bar{D}_{AH} \Delta \phi_H + \bar{D}_{AV} \Delta \phi_V \\ &= \sum_{i=1}^N D_i (\Delta \varepsilon_0 + y_i \Delta \phi_H + z_i \Delta \phi_V) A_i \\ &= \sum_{i=1}^N D_i \{ \Delta \varepsilon_G + (y_i - y_G) \Delta \phi_H \\ &= +(z_i - z_G) \Delta \phi_V \} A_i \end{aligned} \quad (9)$$

Equation (9) can be simply expressed by:

$$\Delta P = (\sum_{i=1}^N D_i A_i) \Delta \varepsilon_G \quad (10)$$

where

$$\Delta \varepsilon_G = \Delta \varepsilon_0 + y_G \Delta \phi_H + z_G \Delta \phi_V. \quad (11)$$

Variables  $y_G$  and  $z_G$  are the coordinates of the center point of ship's cross section, and those are given by the following:

$$y_G = \frac{(\sum_{i=1}^N y_i D_i A_i)}{(\sum_{i=1}^N D_i A_i)} \quad (12)$$

$$z_G = \frac{(\sum_{i=1}^N z_i D_i A_i)}{(\sum_{i=1}^N D_i A_i)} \quad (13)$$

By replacing  $y_i$  and  $z_i$  in Eq.(9) with  $(y_i - y_G) + y_G$  and  $(z_i - z_G) + z_G$ , respectively, and using  $\Delta \varepsilon_G$  from Eq.(11), then Eqs.(8) and (9) can be given in the form:

$$\begin{Bmatrix} \Delta P = 0 \\ \Delta M_H \\ \Delta M_V \end{Bmatrix} = \begin{bmatrix} \bar{D}_{AA} & 0 & 0 \\ 0 & \bar{D}_{HH} & \bar{D}_{HV} \\ 0 & \bar{D}_{VH} & \bar{D}_{VV} \end{bmatrix} \begin{Bmatrix} \Delta \varepsilon_0 \\ \Delta \phi_H \\ \Delta \phi_V \end{Bmatrix} \quad (14)$$

where

$$\begin{aligned} \bar{D}_{AA} &= \sum_{i=1}^N D_i A_i \\ \bar{D}_{HV} &= \bar{D}_{VH} = \sum_{i=1}^N D_i y_i z_i A_i \\ \bar{D}_{HH} &= \sum_{i=1}^N D_i y_i^2 A_i \\ \bar{D}_{VV} &= \sum_{i=1}^N D_i z_i^2 A_i \end{aligned} \quad (15)$$

The bending moment-curvature relationship, Eq.(14), can be applied to the ship hull girder strength by the following loading and/or constraint conditions. The first is the hull girder under pure vertical bending moment:

$$\begin{Bmatrix} 0 \\ \Delta M_V \end{Bmatrix} = \begin{bmatrix} \bar{D}_{HH} & \bar{D}_{HV} \\ \bar{D}_{VH} & \bar{D}_{VV} \end{bmatrix} \begin{Bmatrix} \Delta \phi_H \\ \Delta \phi_V^0 \end{Bmatrix} \quad (16)$$

where the superscript "0" indicates a prescribed value. The solutions are:

$$\begin{aligned} \Delta \phi_H &= -\frac{\bar{D}_{HV}}{\bar{D}_{HH}} \Delta \phi_V^0 \\ \Delta M_V &= \left( \bar{D}_{VV} - \frac{\bar{D}_{VH} \bar{D}_{HV}}{\bar{D}_{HH}} \right) \Delta \phi_V^0 \end{aligned} \quad (17)$$

The second is the hull girder under vertical bending moment with horizontal curvature constrained:

$$\begin{Bmatrix} \Delta M_H \\ \Delta M_V \end{Bmatrix} = \begin{bmatrix} \bar{D}_{HH} & \bar{D}_{HV} \\ \bar{D}_{VH} & \bar{D}_{VV} \end{bmatrix} \begin{Bmatrix} 0 \\ \Delta \phi_V^0 \end{Bmatrix} \quad (18)$$

where the solutions are:

$$\begin{aligned} \Delta M_H &= \bar{D}_{HV} \Delta \phi_V^0 \\ \Delta M_V &= \bar{D}_{VV} \Delta \phi_V^0 \end{aligned} \quad (19)$$

### 3. Case Study

Progressive collapse analysis of hull girders with grounding damage was performed using the Smith Method. A bulk carrier and tanker were used as the object of the analysis as shown in Table 1.

The damage of the bottom part due to grounding was assumed. The horizontal damage extent was considered at the center and asymmetric position of the ship's

breadth for both the bulk carrier and tanker. The longitudinal damage extent was taken as a one-frame space, and it was kept constant for all damaged cases. The damaged cross sections of the bulk carrier and tanker are illustrated in Figures 3 and 4. The stiffness of the elements in the damaged area was completely removed.

**Table 1. Subject Ships**

Ship	Bulk Carrier	Tanker
L (mm)	217,000	234,000
B (mm)	32,236	44,000
D (mm)	18,300	21,200

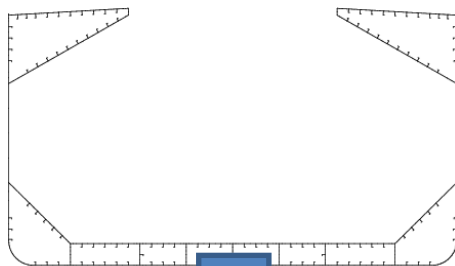

(a) Symmetrical damage (center)

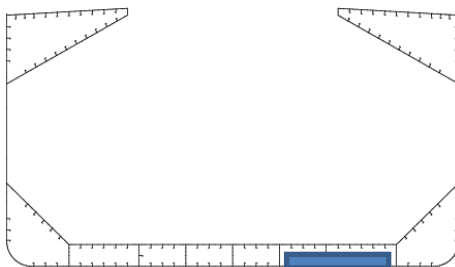

(b) Asymmetrical damage

**Figure 3. Bulk Carrier with Damages**

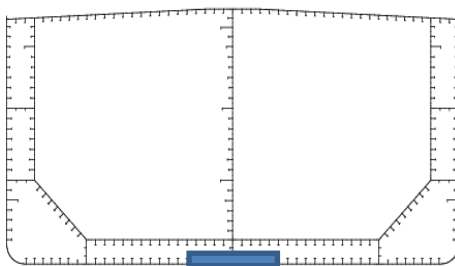

(a) Symmetrical damage (center)

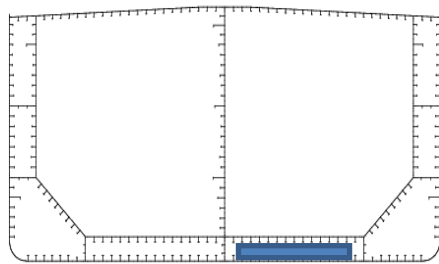

(b) Asymmetrical damage

**Figure 4. Tanker with Damages**

It should be noted that the cross section was assumed to remain plane and perform the simply supported situation for the boundary conditions at both sides of the cross sections.

The analysis for the hull girder strength for both the bulk carrier and proceeds as follows: 1) Subdivide the cross section into elements composed of stiffener and attached plating; 2) Derive the average stress-average strain relationships of individual elements, as shown in Eq.(1), considering the influences of buckling and yielding; 3) Derive the tangential axial stiffness of individual elements,  $D_i$ , shown in Eq.(5), from the average stress-average strain curve at the present strain; 4) Calculate the center position of the neutral axes,  $y_G$  and  $z_G$ , using Eqs.(12) and (13); 5) Evaluate the flexural stiffness of the cross-section with respect to the neutral axis, as shown in Eq.(14); 6) Calculate the curvature and/or bending moment under specified conditions, as shown in Eqs.(16)-(19); 7) Calculate the strain in individual elements from the curvature and their stress using the slope of average stress-average strain curve.

#### 4. Results and Discussion

In case of grounding damage, the ship may also lose its structural stiffness because some the elements at the bottom are broken. Also, when a vertical bending moment is applied to the cross section, the bottom is under compression and the ship may suddenly collapse due to local buckling at the bottom. In the present study, only the stress distributions from the large damage were used for the bulk carrier and tanker to investigate the structural behavior due to grounding damage in hogging and sagging conditions. The stress distributions for the cross section of large grounding damages at the bottom part for bulk carrier are shown in Figures 5 and 6, respectively. The

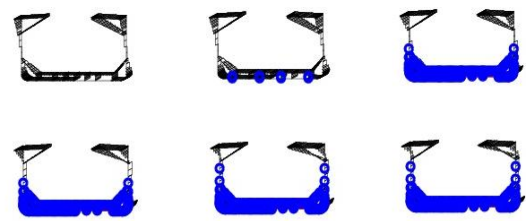

**Figure 5. Large Damage in Hogging Condition for Bulk Carrier**

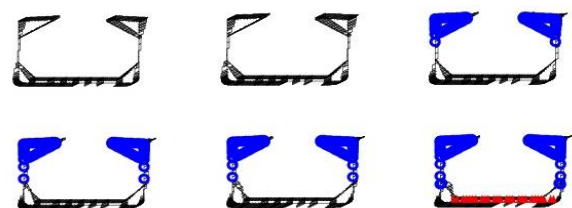

**Figure 6. Large Damage in Sagging Condition for Bulk Carrier**

triangles in the figures indicate the collapsed elements in tension and the circles indicate compression. In the hogging condition, shown in Figure 5, buckling occurs at the bottom first and spreads to the undamaged side. Then, yielding takes place at the deck of the undamaged side, and the ultimate bending moment is attained.

For the case of the tanker, the stress distributions are shown in Figure 7. In the hogging condition, the initially collapsed elements took place both at the bottom and deck areas. Buckling occurred around the damaged area and spread to the undamaged part. At the same time, yielding appeared at the deck area under tension, and the ultimate bending moment was achieved.

Figure 8 shows the stress distribution in the sagging condition. In this regard, buckling took place at the deck area due to compression of some structural elements, and then the ultimate bending moment was attained. The initial yielding did not occur in this condition.

In the sagging condition, buckling occurs at the deck area first and spread to the undamaged side due to the reduction in the load-carrying capacity of the deck, and the ultimate bending moment was reached. In this condition, yielding occurred at the bottom part denoted by the red triangle. The bending moment-curvature relationship for the bulk carrier obtained for the different damage extents are summarized in Figure 9.

For comparison purposes, the horizontal damage extents were considered as small and large. The longitudinal damage extents were considered to be equal with one-frame space for every damage case. The hull girder strength decreased significantly when the grounding damage was assumed to be extended, particularly when

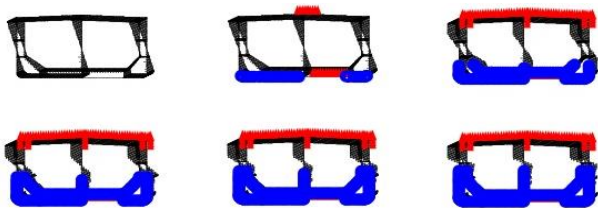

Figure 7. Large Damage in Hogging Condition for Tanker

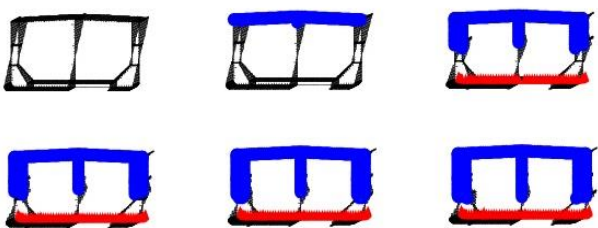

Figure 8. Large Damage in Sagging Condition for Tanker

the ship was under the hogging condition. In the sagging condition, the effect was not significant compared to the hogging one.

Figure 10 shows the moment-curvature relationship for the tanker obtained for small and large horizontal damage extents. It was found that the hull girder strength decreased significantly when the grounding damage was assumed to be extended under the hogging condition, whereas the effect was small when it was in the sagging condition. The bending stiffness for both the bulk carrier and tanker were reduced due to loss of element stiffness in the bottom area. It was also observed that when the grounding damage was located at the center of the bottom part, the influence was not significant compared to the small and large asymmetrical damage.

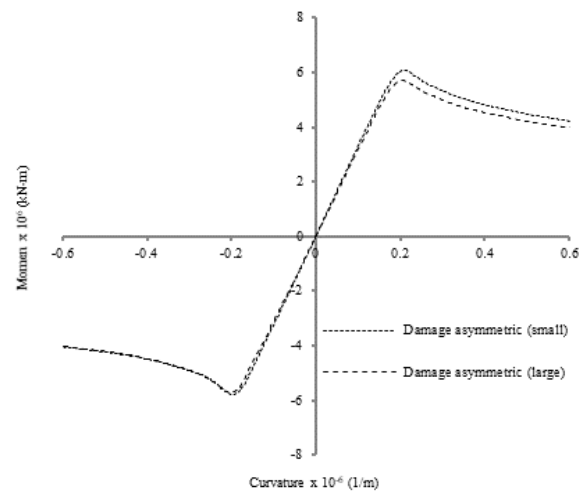

Figure 9. Moment-Curvature Curve for Small and Large Damage Extents of Bulk Carrier

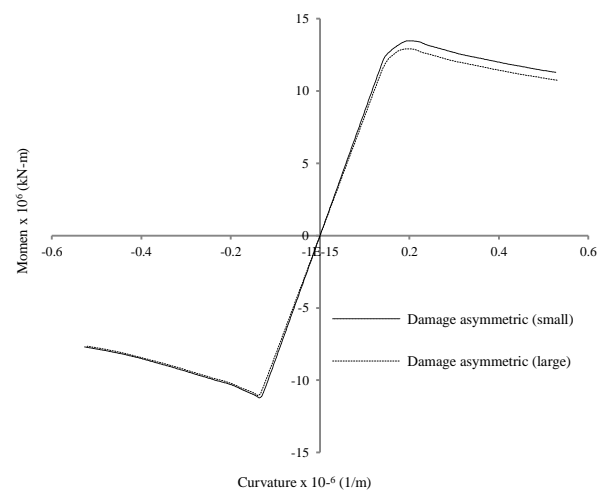

Figure 10. Moment-Curvature Curve for Small and Large Damage Extents of Tanker

Figures 11 and 12 show the summary of the ultimate bending moment capacity-curvature relationship by considering the center, small, and large damage extents, including intact scenarios for the hogging and sagging conditions for the bulk carrier and tanker. It was again found that the hull girder strength was significantly reduced due to the horizontal damage extents for both the bulk carrier and tanker, particularly under the hogging condition. The unloading of the bottom part decreased the bending moment capacity because the grounding damage was considered and simulated to be extended.

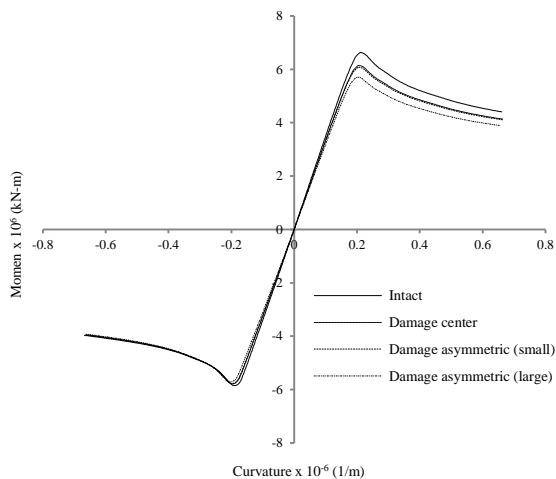

Figure 11. Moment-Curvature Curve of Bulk Carrier

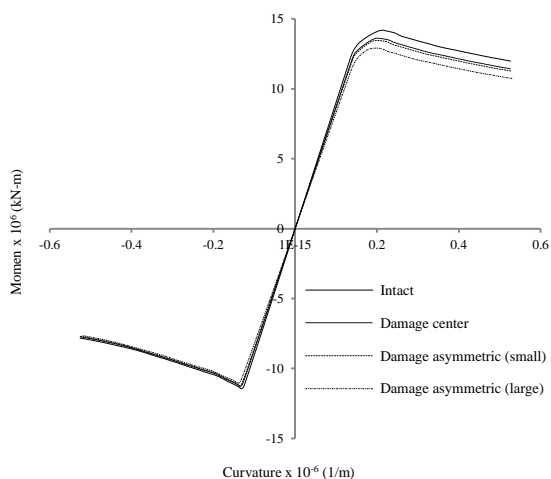

Figure 12. Moment-Curvature Curve of Tanker

The bending moment capacity became large for hogging condition when it was compared with the large horizontal damage extent, but it was not for the sagging one.

The small and large horizontal damage extents significantly affected the bending moment capacity because the large horizontal damage was almost fully half of the ship breadth.

## 5. Conclusion

The analysis of the hull girder strength of a bulk carrier and tanker with grounding damage was conducted using the in-house program based on Smith's Method. The following conclusions were drawn. For the case of grounding damage, which was located at the center of the bottom part, the hull girder strength was not significant, especially when it was compared to asymmetric small damage in the sagging and hogging conditions.

## References

- [1] D.K. Kim, B.J. Kim, J.K. Seo, H.B. Kim, X. Zhang, J.K. Paik. *J. Ocean. Eng.* 76 (2014) 163.
- [2] M.Z. Muis Alie, J. Makara. *Technol.* 20/1 (2016) 7.
- [3] M.Z. Muis Alie. *Proc. Int. Conference on Ship and Offshore Technology.* 01030 (2014) 1.
- [4] M.Z. Muis Alie, et al. *The 35<sup>th</sup> Proc. Int. Conference on Ocean, Offshore and Arctic Engineering (OMAE), Busan, Korea, 2016*, p.104.
- [5] M.Z. Muis Alie, G. Sitepu, S.I. Latumahina, *The 27<sup>th</sup> Proc. Int. Ocean and Polar Engineering Conference (ISOPE), San Francisco, California, USA, 2017*, p.913.
- [6] A. Abubakar, R.S.I. Dow, *J. Solids. Struct.* 50 (2013) 623.
- [7] D.K. Kim, P.T. Pedersen, J.K. Paik, H.B. Kim, X. Zhang, M.S. Kim, *J. Safety Sci.* 59 (2013) 46-54.
- [8] P. Saydam, D.M. Frangopol, *J. Ocean. Eng.* 68 (2013) 65.
- [9] A. Prestileo, A. Rizzuto, A.P. Teixeira, C.G. Soares, *J. Marine Struct.* 33 (2013) 33.
- [10] J. Choung, J.M. Nam, T.B. Ha, *J. Marine Struct.* 25 (2012) 71.
- [11] L. Hong, J. Amdahl, *J. Marine Struct.* 21 (2008) 374.
- [12] O. Ozguc, P.K. Das, N. Barltrop, *J. Marine Struct.* 18 (2005) 511.
- [13] T. Yao, P.I. Nikolov, *J. Soc. Naval. Arch. Japan.* 172 (1992) 437.